

Vacuum Stone Lifter serie O3B

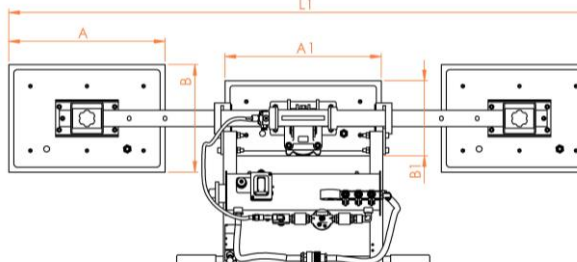
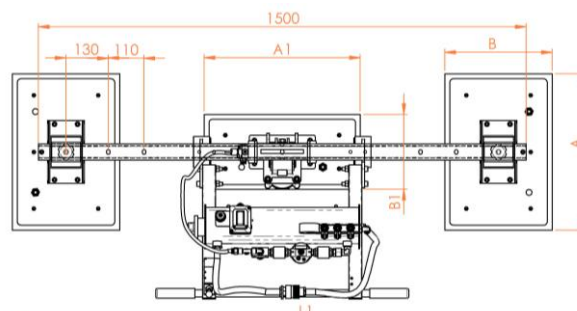
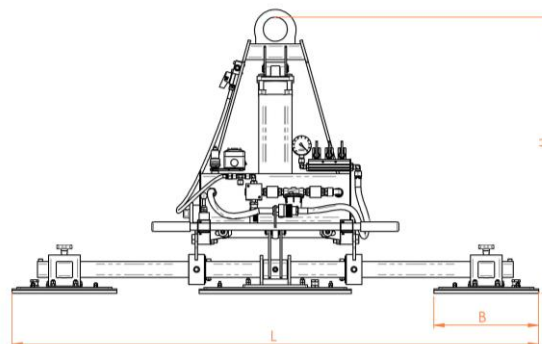

Technical specification

Application	Not porous stones
Lifting capacity	Up to 2000 kg
Suction pads	No. 3 rectangular suction pads
Load movement	0-90° oil dynamic tilt (horizontal/vertical)
Operating system	DC vacuum pump powered by on board batteries High capacity re-chargeable batteries Battery gauge
Vacuum system	Vacuum circuit, complete of vacuum reserve and non return valve
Weight of lifter	Depends on the configuration
Control	Slider valve control for suction/release on the lifter Release of the load by dual action security command
Standard features	On-off double sliding valve with safety Audible and visual low vacuum warning devices Vacuum gauge with colored scale

- electric operating system
- 3 suction pads
- oil dynamic tilting system
- lifting capacity up to 2.000 kg
- low vacuum warning device

Available models

Product code	Lifting capacity	Dimension of pads			
		Central pad		Lateral pads	
		A	B	A	B
03B 375	375	480	230	480	230
03B 625	625	480	230	480	330
03B 750	750	480	330	480	330
03B 900	900	480	330	630	330
03B 1000	1000	630	330	630	330
03B 1200	1200	630	280	630	430
03B 1500	1500	630	430	630	430
03B 2000	2000	630	430	830	430

